

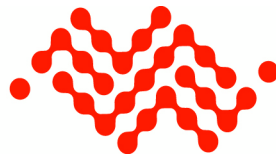

# AirLink Raven XE HSPA

## User Guide



**SIERRA**  
WIRELESS™

20080605  
Rev 4



## Addendum for Raven XE Manual

The information below describes the I/O pin for Raven XE devices with hardware model number H2295\_E<sup>1</sup>:

- Relay output 1 is multiplexed with digital IN 1
- Relay output 1/digital IN 1 has a default voltage of 0VDC
- Digital IN 2 has a default voltage of 3.3VDC
- Relay output 1/digital IN 1 and digital IN 2 both have an independent 51K $\Omega$  pull up resistor to 3.3VDC
- Relay output 1's default is OFF
- When relay output 1 is OFF, relay output 1/digital IN 1=0VDC
- When relay output 1 is driven active low, relay output 1/digital IN 1=3.3VDC

---

1. The hardware model number is printed on the label attached to the device.

## Important Notice

Due to the nature of wireless communications, transmission and reception of data can never be guaranteed. Data may be delayed, corrupted (i.e., have errors) or be totally lost. Although significant delays or losses of data are rare when wireless devices such as the Sierra Wireless modem are used in a normal manner with a well-constructed network, the Sierra Wireless modem should not be used in situations where failure to transmit or receive data could result in damage of any kind to the user or any other party, including but not limited to personal injury, death, or loss of property. Sierra Wireless accepts no responsibility for damages of any kind resulting from delays or errors in data transmitted or received using the Sierra Wireless modem, or for failure of the Sierra Wireless modem to transmit or receive such data.

## Safety and Hazards

Do not operate the Sierra Wireless modem in areas where blasting is in progress, where explosive atmospheres may be present, near medical equipment, near life support equipment, or any equipment which may be susceptible to any form of radio interference. In such areas, the Sierra Wireless modem **MUST BE POWERED OFF**. The Sierra Wireless modem can transmit signals that could interfere with this equipment.

The driver or operator of any vehicle should not operate the Sierra Wireless modem while in control of a vehicle. Doing so will detract from the driver or operator's control and operation of that vehicle. In some states and provinces, operating such communications devices while in control of a vehicle is an offence.

## Limitation of Liability

The information in this manual is subject to change without notice and does not represent a commitment on the part of Sierra Wireless. SIERRA WIRELESS AND ITS AFFILIATES SPECIFICALLY DISCLAIM LIABILITY FOR ANY AND ALL DIRECT, INDIRECT, SPECIAL, GENERAL, INCIDENTAL, CONSEQUENTIAL, PUNITIVE OR EXEMPLARY DAMAGES INCLUDING, BUT NOT LIMITED TO, LOSS OF PROFITS OR REVENUE OR ANTICIPATED PROFITS OR REVENUE ARISING OUT OF THE USE OR INABILITY TO USE ANY SIERRA WIRELESS PRODUCT, EVEN IF SIERRA WIRELESS AND/OR ITS AFFILIATES HAS BEEN ADVISED OF THE POSSIBILITY OF SUCH DAMAGES OR THEY ARE FORESEEABLE OR FOR CLAIMS BY ANY THIRD PARTY.

Notwithstanding the foregoing, in no event shall Sierra Wireless and/or its affiliates aggregate liability arising under or in connection with the Sierra Wireless product, regardless of the number of events, occurrences, or claims giving rise to liability, be in excess of the price paid by the purchaser for the Sierra Wireless product.

## Patents

This product may contain technology developed by or for Sierra Wireless Inc. This product includes technology licensed from QUALCOMM®. This product is manufactured or sold by Sierra Wireless Inc. or its affiliates under one or more patents licensed from InterDigital Group and MMP Portfolio Licensing.

## Copyright

© 2013 Sierra Wireless. All rights reserved.

## Trademarks

Sierra Wireless®, AirPrime®, AirLink®, AirVantage® and the Sierra Wireless logo are registered trademarks of Sierra Wireless.

Watcher® is a registered trademark of Netgear, Inc., used under license.

Windows® and Windows Vista® are registered trademarks of Microsoft Corporation.

Macintosh® and Mac OS X® are registered trademarks of Apple Inc., registered in the U.S. and other countries.

QUALCOMM® is a registered trademark of QUALCOMM Incorporated. Used under license.

Other trademarks are the property of their respective owners.

## Contact Information

### International Contact Information

AirLink Sales	<a href="mailto:airlinksales@sierrawireless.com">airlinksales@sierrawireless.com</a>
AirLink Support*	<a href="mailto:support@sierrawireless.com">support@sierrawireless.com</a>
AirLink RMA Repairs*	<a href="mailto:repairs@sierrawireless.com">repairs@sierrawireless.com</a>
AirLink Online Support Knowledgebase	<a href="http://www.sierrawireless.com/Support/SupportCenter">www.sierrawireless.com/Support/SupportCenter</a>
AirLink Software Downloads	<a href="http://www.sierrawireless.com/Support/Downloads">www.sierrawireless.com/Support/Downloads</a>
Corporate Web Site	<a href="http://www.sierrawireless.com">www.sierrawireless.com</a>

\* If you have purchased your product from an AirLink Distributor or Reseller, please contact them for first line technical support.

---

## Sierra Wireless Headquarters Contact Information

Sales Headquarters:	Phone:	+1-604-232-1488
	Hours:	8:00 AM to 5:00 PM Pacific Time
	E-mail:	<a href="mailto:sales@sierrawireless.com">sales@sierrawireless.com</a>
Post:	Sierra Wireless 13811 Wireless Way Richmond, BC Canada V6V 3A4	

Consult our website for up-to-date product descriptions, documentation, application notes, firmware upgrades, troubleshooting tips, and press releases:

[www.sierrawireless.com](http://www.sierrawireless.com)





# Contents

<b>Introduction to the AirLink Raven XE</b> .....	<b>11</b>
ACEmanager .....	13
ACEview .....	14
Modem Doctor .....	14
Connecting to Your Cellular Provider .....	15
Dynamic vs. Static IP Addresses .....	15
Communications .....	16
HSUPA .....	16
HSDPA .....	16
UMTS .....	17
EDGE .....	17
GPRS .....	17
Connection Methods .....	17
USB Port .....	17
Virtual Serial Port .....	17
Networking .....	18
IPsec .....	18
GRE .....	19
Applications .....	19
Events Reporting .....	19
Software .....	19
Documentation .....	20
Tools and Reference Documents .....	20
<b>Specifications</b> .....	<b>21</b>
Features and Benefits .....	21
Technology .....	21
Bands .....	22
Environmental .....	22
Power Consumption: (@12V DC) .....	22

---

Standards/Approvals . . . . .	22
Host Interfaces . . . . .	23
Physical Specifications . . . . .	23
Application Interfaces . . . . .	23
LED Indicators . . . . .	23
Controls . . . . .	23
Power Connector . . . . .	24
<b>Activating the Raven XE . . . . .</b>	<b>25</b>
Installing the SIM . . . . .	25
Updating Firmware . . . . .	28
<b>Installation of the Raven XE . . . . .</b>	<b>31</b>
Connecting to Power . . . . .	32
Connecting to a Computer or Other Device . . . . .	33
Indicator Lights . . . . .	34
Mounting . . . . .	36
<b>Inputs, Relay Outputs, and Power Status . . . . .</b>	<b>39</b>
Capturing External Events Using Inputs . . . . .	39
Connecting Devices to the I/O Port . . . . .	41
Monitoring the Input and Output . . . . .	42
<b>Connecting the Raven XE . . . . .</b>	<b>43</b>
ACEmanager . . . . .	43
Using a Terminal Application with AT Commands . . . . .	43
AT Commands . . . . .	47
<b>Regulatory Information . . . . .</b>	<b>49</b>
Federal Communications Commission Notice (FCC United States) . . . . .	49
Industry Canada . . . . .	49
RF Exposure . . . . .	50
EU . . . . .	50







# 1: Introduction to the AirLink Raven XE

1

- ACEware™
- Connecting to Your Cellular Provider
- Communications
- Networking
- Applications
- Software
- Documentation

The AirLink Raven XE is an intelligent wireless gateway, powered by ALEOS™ embedded intelligence, and optimal for providing primary or backup network connectivity for any high-reliability/ high-availability applications.

The AirLink Raven XE is the perfect solution for any device with an Ethernet connection that requires pervasive connectivity including PCs, routers, network equipment and POS/ATMs as well as commercial automation equipment.

AirLink Raven XE modems are designed to maintain a reliable, consistent network connection. Class I Division 2 certified as nonincendive equipment, the Raven Series is ideally suited for use in hazardous environments.

Key applications include utilities, manufacturing, automation, oil and gas, Ethernet-based SCADA, telemetry, Homeland Security, and asset monitoring.

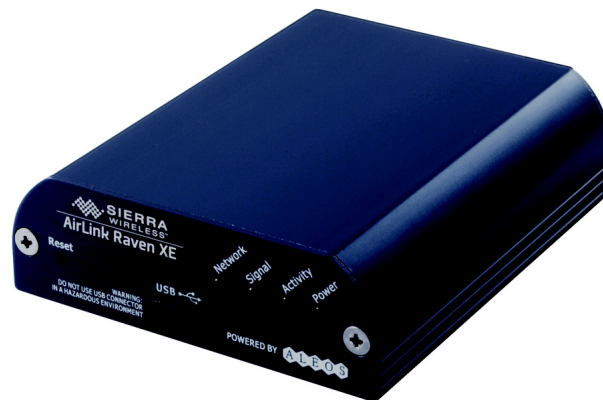

Figure 1-1: AirLink Raven XE

ALEOS, the embedded core technology of Sierra Wireless AirLink products, simplifies the installation, operation, and maintenance of any deployment. In addition, it provides an always-on, always-aware intelligent connection for mission-critical applications.

ALEOS features:

- Persistent Network Connectivity
- Over-The-Air (OTA) Upgrades
- Wireless Optimized TCP/IP
- Real-Time Notification
- Packet Level Diagnostics
- Device Management & Control
- Protocol Spoofing.



Figure 1-2: Powered by ALEOS

## ACEware™

A wireless solution is not complete until you have software tools to manage the devices monitoring your valuable equipment. Using the AirLink Control Environment (ACE), ACEware is the device management and monitoring application suite for Sierra Wireless AirLink devices powered by ALEOS.



Figure 1-3: ACEware Logo

The ACEware suite encompasses an application internal to the firmware (ACEmanager) and the Windows-based applications ACEview, Modem Doctor, ACEnet, and AirLink Management Services (AMS). You can download the ACEview and Modem Doctor applications, and the ACEmanager, ACEnet, ACEview, and ALEOS user guides, from the Sierra Wireless AirLink Solutions website (<http://www.sierrawireless.com/support>). Contact your dealer or Sierra Wireless representative for further information.

---

*Note: ACEview requires the Microsoft .NET Framework v. 2.0 and Microsoft Windows 98, Windows 2000, Windows XP, or later. You can obtain the Microsoft .NET Framework from Microsoft at: <http://www.microsoft.com/>.*

---

## ACEmanager

ACEmanager, the ACEware remote configuration and monitoring tool, simplifies deployment and provides extensive monitoring, control, and management capabilities. ACEmanager gives you the power to manage your Sierra Wireless AirLink communications platforms in real-time.

The screenshot shows the ACEmanager Home Screen with a navigation menu at the top and a main content area. The navigation menu includes: Status, WAN/Cellular, LAN/WiFi, VPN, Security, Services, GPS, Serial, Applications, I/O, Admin, and Events Reporting. The main content area displays the following data:

Category	Parameter	Value
Home	AT Phone Number	5106735137
WAN/Cellular	AT IP Address	75.210.40.160
LAN/WiFi	AT Network State	Network Ready
VPN	AT RSSI (dBm)	-90
Security	AT Network Operator	Verizon
Services	AT Network Service Type	1X_EV-DO_Rev_A
GPS	AT ALEOS Software Version	MP_S97W4.0.10.B01 Jun 17 2011
Serial	AT ECIO (dB)	-6.5
Applications	AT Channel	1175
About	WAN/Cellular Bytes Sent	34976471
	WAN/Cellular Bytes Rcvd	12952662
	AT Device Name	billybob

Buttons for Apply, Refresh, and Cancel are visible in the top right corner of the main content area.

Figure 1-4: ACEmanager Home Screen

## Simplified Deployment

ACEmanager provides the ability to remotely set up and configure your Sierra Wireless AirLink products. Remote device setup and configuration reduces the deployment timeline of your wireless solution and provides a quicker path to ROI.

Templates allow you to easily configure devices in your fleet with identical settings, ensuring a simple, accurate deployment.

## Monitor and Control

ACEmanager allows an administrator to remotely monitor a modem's status, health and configuration settings. The user interface displays signal strength, cell site information, byte counters and error conditions, enabling you to pinpoint any issues and troubleshoot immediately.

ACEmanager enables remote configuration and parameter settings to be changed or reset instantly over the air, change a device's port configuration, IP address settings, GPS settings, and much more. After configuring one modem, use the template feature to copy that device configuration to other devices.

---

**Tip:** *The configuration steps and examples in this user guide use ACEmanager.*

---

## ACEview

ACEview is an efficient status and connection monitoring application with a low-profile, easy to read interface. In ACEview, you can also update the PRL (Protocol Roaming List) on a device.



Figure 1-5: ACEview Main Screen

## Modem Doctor

Modem Doctor and Modem Doctor USB is a troubleshooting and diagnostics utility. This utility allows you to get a log file of the AirLink Raven XE activity which you can then send to Sierra Wireless support or erase the current configuration completely.

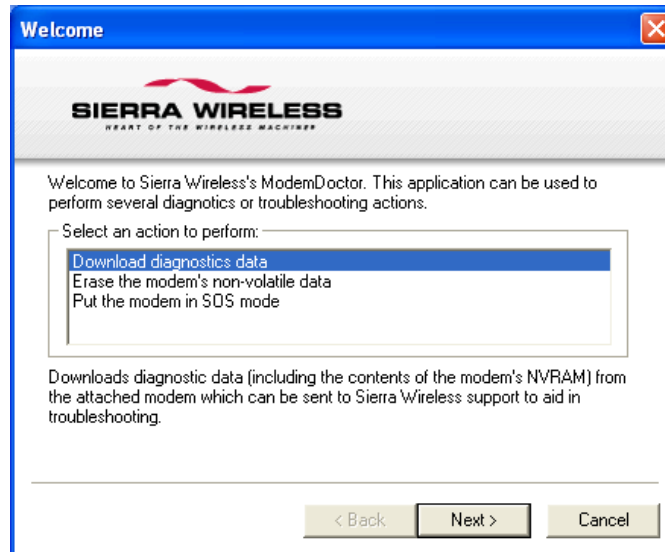

Figure 1-6: Modem Doctor

## Connecting to Your Cellular Provider

The AirLink Raven XE uses your cellular provider as an ISP (Internet Service Provider) to connect you to the Internet.

### Connection Steps:

1. Your AirLink Raven XE establishes a PPP (Point to Point Protocol or “dial up” connection) link to the cellular provider’s network, also called registering on the network, and receives an IP address.
2. When your AirLink Raven XE has received its IP address from your cellular provider, a connection to the Internet or the cellular network is also available for computers or other devices connected directly to the AirLink Raven XE.

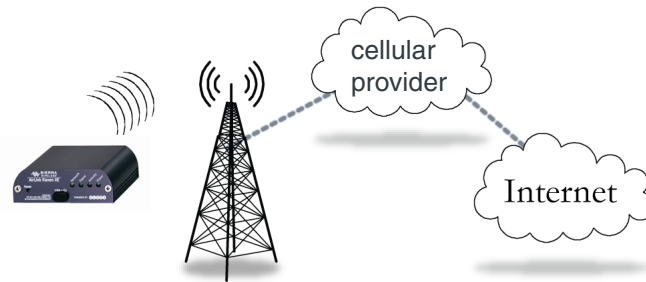

The AirLink Raven XE will perform routing for all internet traffic to and from the computers or other host devices.

With the AirLink Raven XE in Ethernet Public mode, only one device connected to the Ethernet port will receive the public IP address which is the one provided by the cellular network. In Ethernet Private mode, with a hub or switch connected to the Ethernet port, the AirLink Raven XE will provide NAT for a range of computers or other devices connected to the switch or hub and Internet access to all of them.

## Dynamic vs. Static IP Addresses

There are two types of addresses on networks: dynamic and static.

- Dynamic addresses are assigned on a “need to have” basis. Your AirLink Raven XE might not always receive the same address each time it connects with your cellular provider.
- Static addresses are permanently assigned to a particular account and will always be used whenever your AirLink Raven XE connects to the Internet. The IP address will not be given to anyone else.

Most ISPs (cellular included) use dynamic IP addresses rather than static IP addresses since it allows them to reuse a smaller number of IP addresses for a large number of customers. A dynamic IP address is suitable for many common Internet uses, such as web browsing, looking up data on another computer system, or other client functions (such as data only being sent out or only being received after an initial request).

---

**Tip:** *If your account with your cellular provider includes a dynamic IP address and you need a static IP, please consult your cellular provider representative for more information about changing your account for static IP support.*

---

If you need to contact your AirLink Raven XE, a device connected to the AirLink Raven XE, or a host system using the AirLink Raven XE from the Internet, you need to have a known IP (such as one which is static) or domain name (an IP address which is converted by a DNS server into a word-based name). If you have a dynamic IP address for your modem, you can use a Dynamic DNS service (such as Sierra Wireless's IP Manager) to translate your IP address into to a domain name.

---

**Caution:** *If you want to connect remotely to your AirLink Raven XE using TCP/IP or UDP/IP, the IP address given to your modem by your cellular provider cannot be a private or internal IP address (such as a special private network) unless you are on the same network or inside that network's firewall (such as with frame relay).*

---

## Communications

GSM networks use SIM cards which are smart cards containing the account holder's details. A SIM can generally be moved from one device to another allowing for account portability and flexibility.

### HSUPA

HSUPA (High-Speed Uplink Packet Access) is a cellular technology which most closely resembles a broadband synchronous connection. The upload and download speeds are maximized to provide a faster throughput, reaching speeds up to 2.0 Mbit/s for the uplink and 7.2 Mbit/s for the downlink.

Please check with your network provider on the availability of HSUPA.

### HSDPA

HSDPA (High-Speed Downlink Packet Access) is a cellular technology allowing for higher data transfer speeds. In HSDPA mode of operation, max speeds are up to 7.2 Mbit/s in the downlink and 384 kbit/s in the uplink. HSDPA uses Adaptive Modulation and Coding (AMC), fast packet scheduling at the Node B (Base Station) and fast retransmissions from Node B (known as HARQ-Hybrid Automatic Repeat Request) to deliver the improved downlink performance vs. UMTS and EDGE.

HSPDA (and HSUPA) falls back to UMTS, EDGE, or GPRS (in order of precedence). This feature allows you to have seamless connectivity no matter where your AirLink Raven XE is.



## UMTS

UMTS (Universal Mobile Telecommunications System) supports data transfer rates of up to 1920 kbit/s; most users can expect performance up to 384 kbit/s. A UMTS network uses a pair of 5 MHz channels: one in the 1900 MHz range for uplink, and one in the 2100 MHz range for downlink.

## EDGE

EDGE (Enhanced Data rates for GSM Evolution) provides end-to-end packet data services with an enhanced connectivity building on GPRS technology and using the established GSM networks. EDGE provides higher transmission rates and better transmission quality for data than GPRS. EDGE can carry data at speeds typically up to 384 kbit/s in packet mode.

When EDGE is not available, your AirLink Raven XE will fall-back to GPRS for the connection to Sprint to provide continued connectivity.

## GPRS

General Packet Radio Service (GPRS) is packet-switched with many users sharing the same transmission channel, but only transmitting when they have data to send. This means that the total available bandwidth can be immediately dedicated to those users who are actually sending at any given moment, providing higher use where users only send or receive data intermittently. GPRS provides speeds of 30 - 70 kbps with bursts up to 170 kbps.

## Connection Methods

You can connect the AirLink Raven XE to a USB or an Ethernet (RJ45) port on a computer. When connected to a USB or Ethernet port, the AirLink Raven XE behaves like a network card.

### USB Port

The AirLink Raven XE is equipped with a USB port which increases the methods by which you can send and receive data. The USB port can be set to work as either a virtual Ethernet port or a virtual serial port. A driver installation is required to use the USB port in either mode. USB drivers can be downloaded from the Sierra Wireless AirLink Solutions web site: <http://www.sierrawireless.com/support>.

It is recommended that you use a USB 2.0 cable with your AirLink Raven XE and connect directly to your computer for best throughput.

### Virtual Serial Port

The AirLink Raven XE supports one virtual serial port over USB. This VSP can be used, for example, to send AT commands, or to run many serial based applications such as HyperTerminal®.

# Networking

## IPsec

The IP protocol that drives the Internet is inherently insecure. Internet Protocol Security (IPsec), which is a standards-based protocol, secures communications of IP packets over public networks.

IPsec is a common network layer security control and is used to create a virtual private network (VPN).

The advantages of the IPsec feature includes:

- **Data Protection:** Data Content Confidentiality allows users to protect their data from any unauthorized view, because the data is encrypted (encryption algorithms are used).
- **Access Control:** Access Control implies a security service that prevents unauthorized use of a Security Gateway, a network behind a gateway or bandwidth on that network.
- **Data Origin Authentication:** Data Origin Authentication verifies the actual sender, thus eliminating the possibility of forging the actual sender's identification by a third-party.
- **Data Integrity:** Data Integrity Authentication allows both ends of the communication channel to confirm that the original data sent has been received as transmitted, without being tampered with in transit. This is achieved by using authentication algorithms and their outputs.

The IPsec architecture model includes the Sierra Wireless AirLink gateway as a remote gateway at one end communicating, through a VPN tunnel, with a VPN gateway at the other end. The remote gateway is connected to a Remote network and the VPN is connected to the Local network. The communication of data is secure through the IPsec protocols.

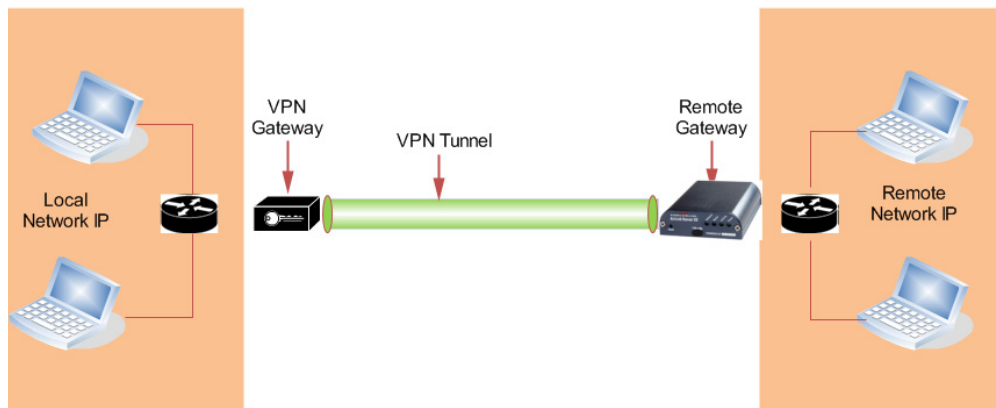

Figure 1-7: IPsec Architecture

## GRE

GRE (Generic Routing Encapsulation) tunnel is used to carry non-IP packets through an IP Network. Non-IP packets sent over the GRE tunnel must first be encapsulated. Hence, ALEOS is used to configure and encapsulate non-IP packets and transmit over IP through the GRE tunnel.

## Applications

### Events Reporting

Events Reporting is a Sierra Wireless AirLink modem software feature, provided via ACEmanager, that allows users to generate reports from the events that take place. Event Reporting Protocol is an intuitive embedded protocol, which automatically formats the messages based on an event trigger. The messages generated are then reported to the remote server.

## Software

The AirLink Raven XE device comes with the following software:

- ACEview, the software for the AirLink Raven XE which allows you to monitor your connections.
- The driver that forms the interface between the AirLink Raven XE and your Windows operating system when using USB virtual Ethernet or USB virtual serial.
- Firmware that is stored in non-volatile memory and includes ACEmanager.

The AirLink Raven XE has an embedded radio module made by Sierra Wireless. There are two firmware programs on the device—one stored on the controller board of the AirLink Raven XE and one on the radio module.

The firmware was loaded into the controller board and radio module when the AirLink Raven XE was assembled. As new versions of the software and firmware are released, they are posted at [www.sierrawireless.com](http://www.sierrawireless.com).

---

*Note: The radio module firmware is not updatable; only ALEOS-level firmware can be updated.*

---

## Documentation

This *Raven XE User Guide* describes how to:

- Install the AirLink Raven XE hardware.
- Connect the radio antennas.
- Connect a notebook computer and other input/output (I/O) devices.
- Install the software.
- Interpret the LEDs on the AirLink Raven XE and the indicators in the ACEview software.

This *Raven XE User Guide* is provided as a PDF (Portable Document Format) file on the installation CD or from the Sierra Wireless support website.

## Tools and Reference Documents

User Guide	Description
<b>ALEOS User Guide</b>	This document discusses software configuration in ACEmanager and explains all the ALEOS features.
<b>ACEview User Guide</b>	This document explains the use of the utility tools which are used to view and monitor the connection state of a Sierra Wireless AirLink device.
<b>ACEnet User Guide</b>	This document explains the use of ACEnet services for the remote management of Sierra Wireless AirLink devices.

## 2: Specifications

- Features and Benefits
- Technology
- Bands
- Environmental
- Power Consumption: (@12V DC)
- Standards/ Approvals
- Host Interfaces
- Physical Specifications
- Application Interfaces
- LED Indicators
- Controls
- Power Connector

### Features and Benefits

- Embedded Intelligence
- Low Power Consumption
- Compact Size
- Rugged Aluminum Case
- High-Speed Processor (ARM 9)
- High-Speed 2-way Data
- 10/100 Mbps Ethernet Port
- Persistent Network Connectivity
- Remote Management and Configuration
- Class1 Div 2 Certified

### Technology

HSPA with fallback to:

- HSUPA
- HSDPA
- UMTS
- EDGE
- GPRS (MS-12)
- GSM

## Bands

- TriBand (3G) for UMTS/HSDPA/HSUPA
  - 850/1900/2100 MHz
- Quad Band (2G) GPRS/EDGE
  - 850/900/1800/1900 MHz

## Environmental

- Operating Temperature:
  - -30° to 70° C (-22° to 158° F)
- Storage Temperature:
  - -40° to 85° C (-40° to 185° F)

## Power Consumption: (@12V DC)

- Transmit/Receive (Typical/Max) 120/230 mA
- Idle 90 mA
- Input Voltage 7 - 28 VDC

## Standards/Approvals

---

*Note: In consideration of EU regulations, this device is classified as a Class A device for use in commercial environments.*

---

- CE/EU
- Carrier specific approvals
- RoHS
- FCC
- Industry Canada
- Mil-Spec 810-F Certified
- This apparatus is suitable for use in Class 1, Division 2, Groups A, B, C, D, or unclassified or non-hazardous locations.



---

**Warning:** *Explosion Hazard - Substitution of any components may impair suitability for Class 1, Division 2.*

---

---

*Note: The device fulfills only Class A limits.*

---

---

## Host Interfaces

- Ethernet: 10BaseT RJ-45
- USB Type B5 Pin mini
- Antenna Connection:
  - Primary Cellular - 50 Ohm SMA
  - Receive Diversity - 50 Ohm SMA
  - One digital input port, one digital I/O port



---

**Warning:** *The antenna should not be installed closer than 20 cm from any people. It is one of the RSS-102 requirements for devices not requiring SAR.*

---

## Physical Specifications

- Dimensions (H x W x D)
  - 27 mm x 75 mm x 103 mm (1.06 in x 2.95 in x 4.06 in)
- Weight
  - 185 grams/.41 lb.

## Application Interfaces

- TCP/IP, UDP/IP, DHCP, HTTP, SNMP, SMTP, SMS, MSCI, Binary, Modbus, and others

## LED Indicators

- Network
- Signal
- Activity
- Power

## Controls

- Reset button

## Power Connector

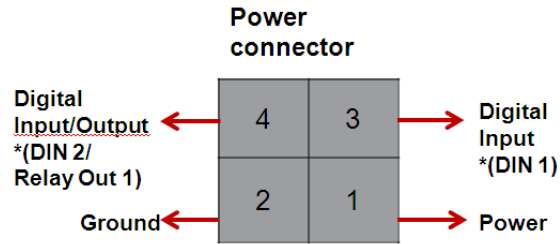

\* Configuration terminology in ACEmanager

Figure 1-8: Power Connector (not to scale)

---

**Warning:** *Explosion Hazard - Do not disconnect equipment unless power has been switched off or the area is known to be non-hazardous.*

---

*Note: Raven XE I/O Port is software configurable.*

---





## 3: Activating the Raven XE

3

- [Installing the SIM](#)
- [Updating Firmware](#)

This chapter provides step-by-step directions for activating your Raven XE on your cellular provider's network.

### Installing the SIM

The Subscriber Identity Module (SIM) in the Raven XE is a smartcard that securely stores the key identifying a cellular subscriber. Generally, you will only need to install a SIM once in the life of the modem, and it may be pre-installed by your Sierra Wireless representative.

If the SIM was pre-installed, unless you need to set a custom APN, activation of your modem is complete.

### Cellular Account Required

- **Cellular Account Required**- To use your modem, you need to have a SIM with an active account in a data plan with your cellular provider (EDGE or HSUPA/HSDPA).

### Software Required

ACEmanager is a software utility that is provided with your Airlink device at no additional cost. Follow the steps below to connect to ACEmanager for configuring the modem.

- Ensure Raven XE connectivity to access ACEmanager.
- Go to: <http://192.168.13.31:9191> the first time you connect to ACEmanager.

ACEmanager supports the current Internet Explorer and Firefox browser versions for Microsoft Windows 7 and Windows XP.

### Hardware Required

- **Ethernet cable**

---

*Note: Until you install a driver for the USB port, you cannot use your USB port to configure the modem.*

---

- **Power adapter and power source** - You will need a power supply and power source for the modem.
- **PC or laptop** - To configure the modem, you will need a computer with an available Ethernet port or serial port.

## Tools Required

- **Small Phillips screw driver** - The Phillips screw driver is also called a plus (+) or X screw driver.
- **Slim stylus** - A PDA stylus, an unbent paperclip, or any other such item.

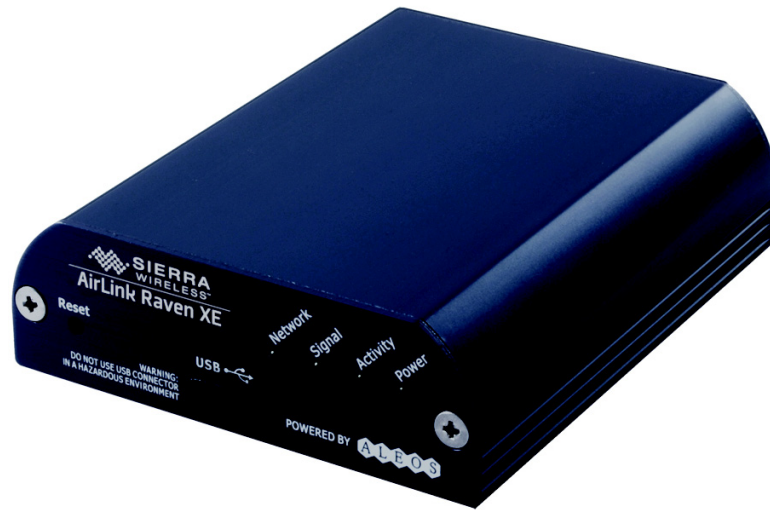

Figure 3-1: Raven XE Faceplate



**Warning:** Explosion Hazard. Do not remove or replace Plug-in Modules unless power has been disconnected or the area is known to be free of ignitable concentrations of flammable Gasses or vapors.

---

1. Open the Case.
  - a. Unplug the Raven XE power cable and all other cables.
  - b. Using a small Phillips head screw driver, remove the screws on the back of the Raven XE.
2. Remove the SIM from the card.
  - a. Carefully remove the SIM card from the card you received from your cellular provider.
3. Insert the SIM.
  - a. Gently press the SIM card in to click it into place.

---

**Tip:** The top of the card faces the bottom of the modem.

---

---

*Note: The card and SIM may be a different color than these examples.*

---

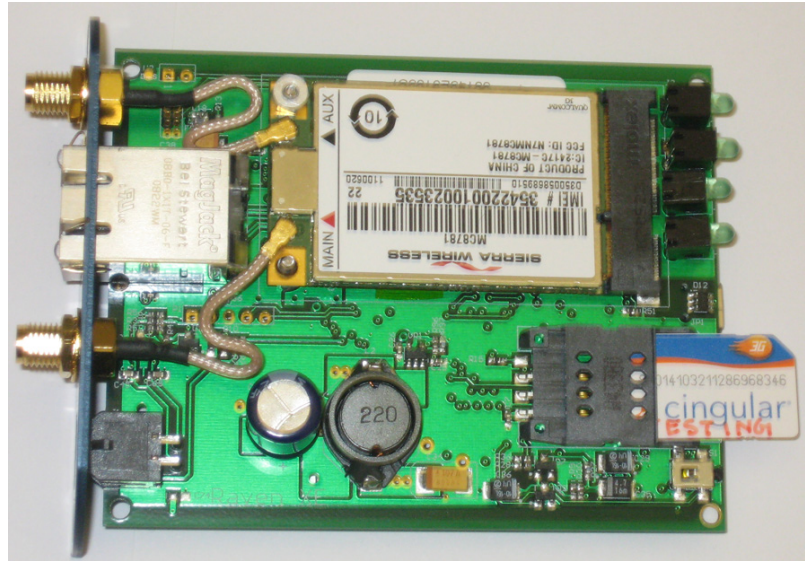

Figure 3-2: Insert SIM into the modem

#### 4. Finish the SIM installation.

When the faceplate is replaced and secured, the installation of the SIM is complete. Secure the front of the Raven XE with the Phillips screws.

The APN (Access Point Name) is the way your modem knows how it will be communicating with the network. The APN allows custom IP addressing and tailors your company's wireless IP solution to meet the security and IP addressing requirements of your applications.

---

*Note: Most accounts use the default addressing solution of Private or Public IP addresses supplied by the Internet and Proxy APNs. You should only need to configure a custom APN if you have a Static or Custom IP address.*

---

The default APN is *Internet*. If you need a different APN, use ACEmanager to configure it.

## Updating Firmware

To install the latest firmware version (.exe file), go to the Sierra Wireless website: <http://www.sierrawireless.com>.

For the updated tool to execute, install the USB drivers available on the website before executing the .exe file.

---

**Tip:** Copy the *USB Serial Driver.inf* file to your desktop. Next, power up the Raven XE and connect the USB. Install from a specific location and point to this .inf file. For detailed instructions on installing the USB drivers, refer to *Universal Serial Bus Application Note*.

---

1. Connect the Raven XE to your computer with either an Ethernet or USB cable.
2. Connect the power adapter and antennas to your Raven XE.
  - a. A Sierra Wireless firmware update welcome screen displays. Click on Next.



Figure 3-3: Launch Screen

- b. Choose the interface you want to program the modem through, and click on Next.

The default Private for Ethernet is also in a different subnet from the other connection types.

Table 3-1: Factory Defaults

Interface	Raven XE	Connected Device
Ethernet Private default	192.168.13.31*	192.168.13.100
USB/NET	192.168.14.31	192.168.14.100
DUN	192.168.15.31	192.168.15.100

\*Can be changed via ACEmanager

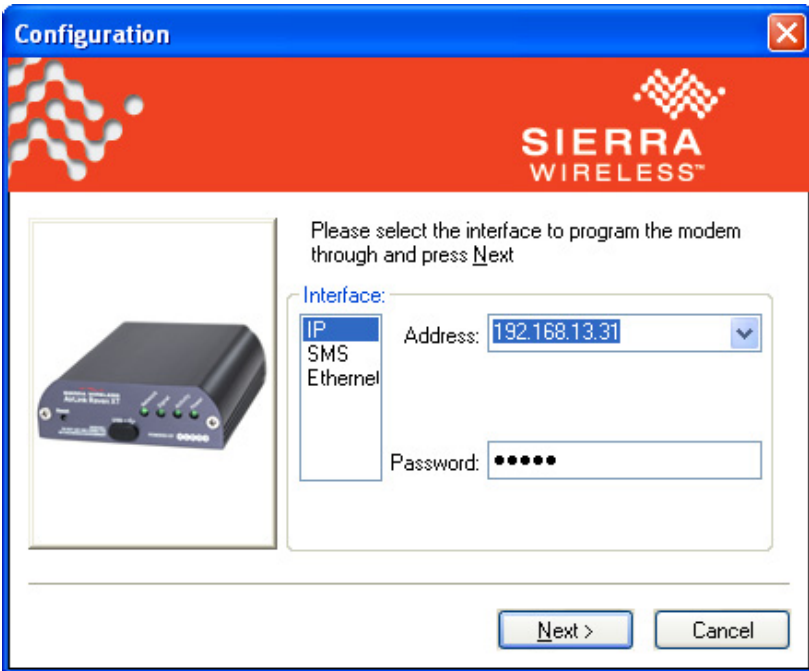

Figure 3-4: Configuration: Interface selection

- c. The next screen will prompt you to reset the modem manually. Reset the modem, and click on Next.

Installation begins and can take up to a few minutes. Once the installation is complete, you will get a confirmation screen.



## 4: Installation of the Raven XE

- Connecting to Power
- Connecting to a Computer or Other Device
- Indicator Lights
- Mounting

*Note: During installation, please be sure that the cables are secure but do not bear any additional weight that could loosen the connector from the unit.*

Your Raven XE should be mounted in a position that allows easy access for the cables so they are not bent, constricted, in close proximity to high amperage, or exposed to extreme temperatures. The LEDs on the front panel should be visible for ease of operational verification. You should ensure that there is adequate airflow around the modem but that it is kept free from direct exposure to the elements, such as sun, rain, dust, etc.

**Caution:** *The Raven XE is in a hardened case and designed for use in industrial and extreme environments. However, unless you are using cables expressly designed for such environments, they can fail if exposed to the same conditions the Raven XE can withstand.*

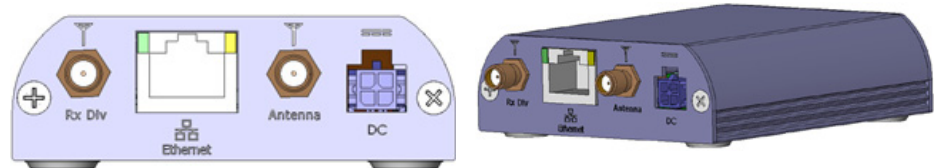

Figure 4-1: Raven XE Connectors

*Note: A distance of at least 20 cm between the antenna and the user's body must be maintained at all times.*

Antennas selected should not exceed a maximum gain of 5 dBi under standard installation configuration. In more complex installations (such as those requiring long lengths of cable and/or multiple connections), it's imperative that the installer follow maximum dBi gain guidelines in accordance with the radio communications regulations of the Federal Communications Commission (FCC), Industry Canada, or your country's regulatory body (if used outside the US).

Your Raven XE will work with most PCS cellular antennas with an SMA connector that works in the high and low frequencies of the cellular technology of your modem. Connect the primary antenna or primary RF cable directly to the antenna connector on the back of the Raven XE.

**Tip:** When using a cable connected to an antenna placed away from the modem, minimize the length of your cable. All gain from a more advantageous antenna placement can be lost with a long cable length to the modem.

To provide for diversity in the signal reception, connect the second antenna to the second antenna port (SMA, labeled Rx Div ANT2) on the back of the Raven XE.

**Caution:** If you are not using a diversity antenna, you should disable the receive diversity option. In ACEmanager, in the WAN/Cellular group, configure RX Diversity.

## Connecting to Power

The Raven XE digital I/O port consists of a 4-pin power connector which includes two digital I/O ports. Port 4 is software configurable, while Port 3 is digital input only and not software configurable.

The I/O port handles external input and output events. An external device can send digital input to the modem through the digital I/O port.

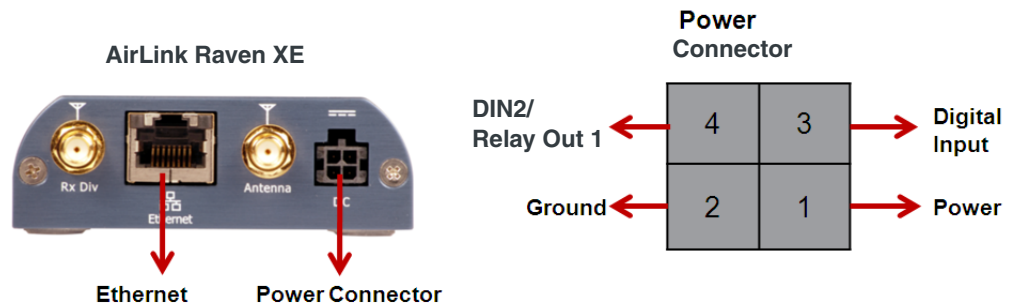

Figure 4-2: Digital I/O Port: Power Connector



**Warning:** Risk of electric shock: Only use the supply voltages listed in this user guide.



**Warning:** The operating temperature range of the 12V AC power adapter is 0<sup>o</sup> - 40<sup>o</sup>C. This range is less than the operating temperature range of the Raven XE. For deployments in more extreme temperatures, use the optional DC power cable rather than the AC power adapter.

With the appropriate power adapter, the Raven XE can be used with either DC or AC power. DC cables and AC adapters are available as optional accessories in addition to the one included with your Raven XE.



---

*Note: When using a DC power source (e.g., a solar cell), Sierra Wireless recommends placing a fuse (1-2 Amp) on the line close to the power source to protect your power source from possible surges due to shorts or other line issues.*

---

The DC power cable positive lead should be connected to the battery or power source positive terminal. The power cable negative lead should be connected to the battery or power source negative terminal.

---

**Tip:** *The DC power cable has a white wire lead in addition to the power positive and negative. This is for a feature not present in the Raven line modems. In the Raven XE, the white wire lead has no function and can be ignored.*

---



**Warning:** *Explosion Hazard - Do not disconnect equipment unless power has been switched off or the area is known to be non-hazardous.*

---

## Connecting to a Computer or Other Device

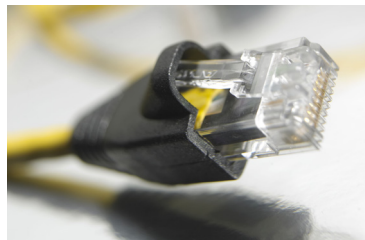

Figure 4-3: Ethernet connector

The Ethernet port of your Raven XE can be connected directly to a computer or other Ethernet device with either a cross-over cable or a straight-through cable. The Ethernet port on the Raven XE is auto-sensing and connects at 100baseTX. If you are connecting the modem to a hub or switch you should use a straight through cable or use the uplink port on the hub or switch with a cross-over cable.

---

**Tip:** *On some computers, the TCP receive window may be set to 16 kbytes. To optimize the throughput of your Raven XE, it is recommended that you change the TCP window from 128 kbytes to 256 kbytes using a TCP Optimizer.*

---



Figure 4-4: USB connector

Your Raven XE's full-speed (12 Mbit) USB 2.0 port can be connected directly to most computers or other devices using a standard full-speed USB 2.0 cable. If the computer or device you are connecting or the cable is not rated for full-speed, the modem will communicate at a reduced speed to match. The Raven XE functions as a device and not as a host.

When it is connected to a computer, the USB port should be seen as a COM port or an Ethernet port after the applicable driver is installed.

The Raven XE has a standard mini-B connector.



---

**Warning:** *The USB port can only be used in a non-hazardous environment.*

---

## Indicator Lights

When your Raven XE is connected to power and an antenna, there is a specific pattern to the lights to indicate its operation mode.

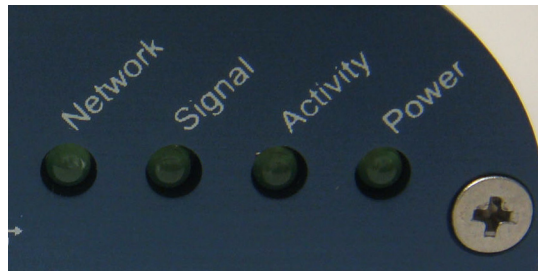

Figure 4-5: Indicator lights

- **Network** - When lit solid, indicates a successful connection to the cellular network with an IP address given and a channel acquired. A tri-mode LED, Network blinks slowly while searching for cellular service, blinks faster once it finds cellular service and is attempting to authenticate on the cellular network, and finally is solid when the device is authenticated on the cellular network and is provided an IP address by the cellular network.
- **Signal** - Light shows the strength of the signal and may be nearly solid (strong signal) or flashing (weaker signal). A slow flash indicates a very weak signal.

**Table 4-1: RSSI LED Ranges**

<b>RSSI/Signal LED Status</b>	<b>Ranges of RSSI (dBm)</b>
On Solid	Equal to or stronger than -69
Fast Blink	-70 to -79
Normal blink	-80 to -89
Slow Blink	-90 to -99
Extinguished	Equal to or weaker than -100

- **Activity** - Lights will flash as data is transferred to and from the Raven XE on the remote network.
- **Power** - Indicates the power adapter is connected and there is power getting to the Raven XE.
- The **Reset button** (on the left side of the Raven XE) has two functions. If it is quickly depressed and released, the modem will simply power cycle the internal hardware. If, however, the reset is depressed and held for several seconds (count approximately 30 seconds, and wait for the power light to go off after the light pattern stops), the ALEOS configuration settings will return to the factory defaults.

---

**Caution:** *If you reset the modem configuration using the Reset button, you may need to reconfigure your APN.*

---

## Light Patterns

The LEDs on the front of the modem will respond in different patterns to indicate modem states.

- **Normal** - Each LED, mentioned above, is lit as applicable.
- **Start up** - The LEDs will cycle from left to right.
- **Configuration Reset** - The LEDs will cycle left to right and then right to left 4 times.
- **Authentication Failure** - The Network, Signal, and Activity LEDs blink every 2 seconds.
- **Data Retry** - The Network, Signal, and Activity LEDs blink every 3 seconds.

## Mounting

An optional accessory for your Raven XE is a mounting kit, which includes a bracket. The bracket is designed to snugly cradle the modem and hold it in place where you need it. You can use a strap around the bracket and modem for extra security. The bracket can be attached to a stationary location using #6 screws with the mounting hole diameter approximately 0.15 inches.

Bracket installation instructions are as follows:

1. Mount the bracket using #6 screws. There are two holes on each side of the bracket to fasten the screws, and at least one hole on each end is required for mounting the bracket.
2. Position Raven XE between the alignment ears.
3. Engage the top groove in the body of the Raven XE with the two tabs.
4. Push in the center on the far side of the Raven XE so that it touches the side of the bracket.
5. Press down, and release when the upper groove on the far side of the Raven XE aligns with the tabs.
6. Installation into the mounting bracket is complete.

To remove the Raven XE, press on the two edges of the modem and the bracket. By doing this, the modem will snap out of the mounting bracket.

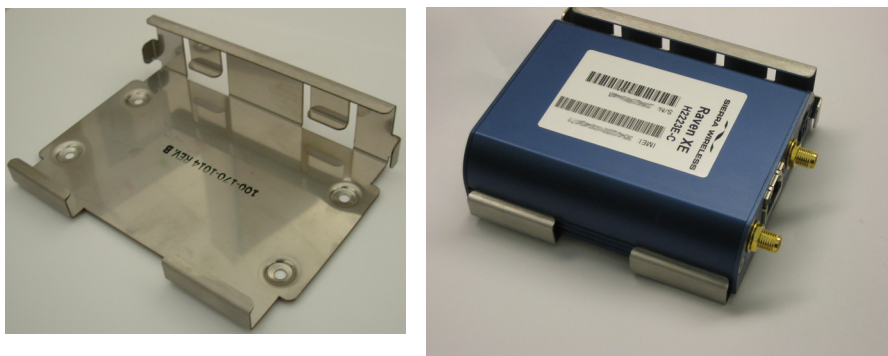

Figure 4-6: Optional Mounting Bracket

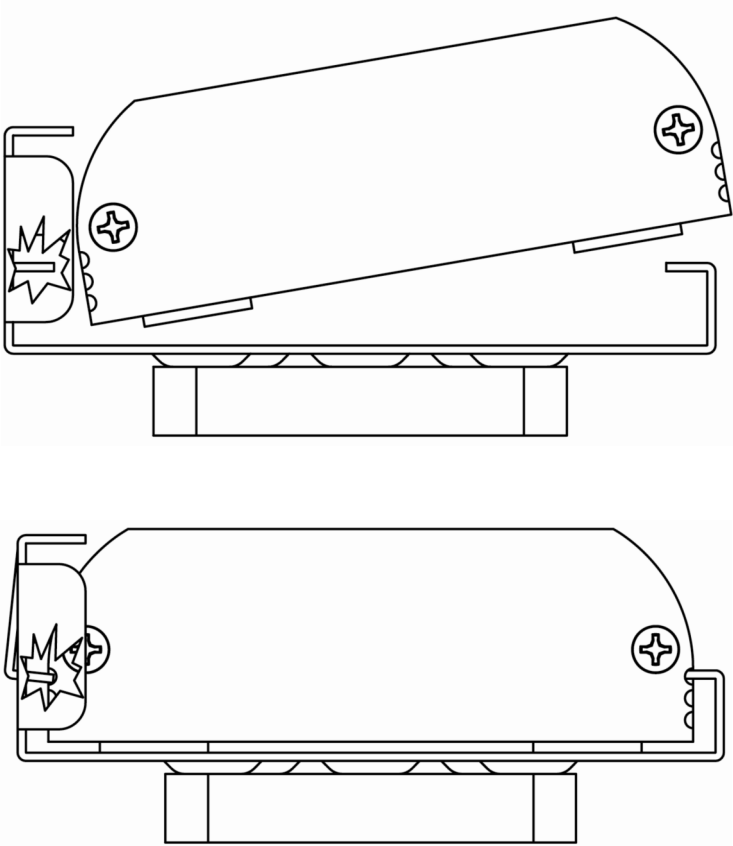
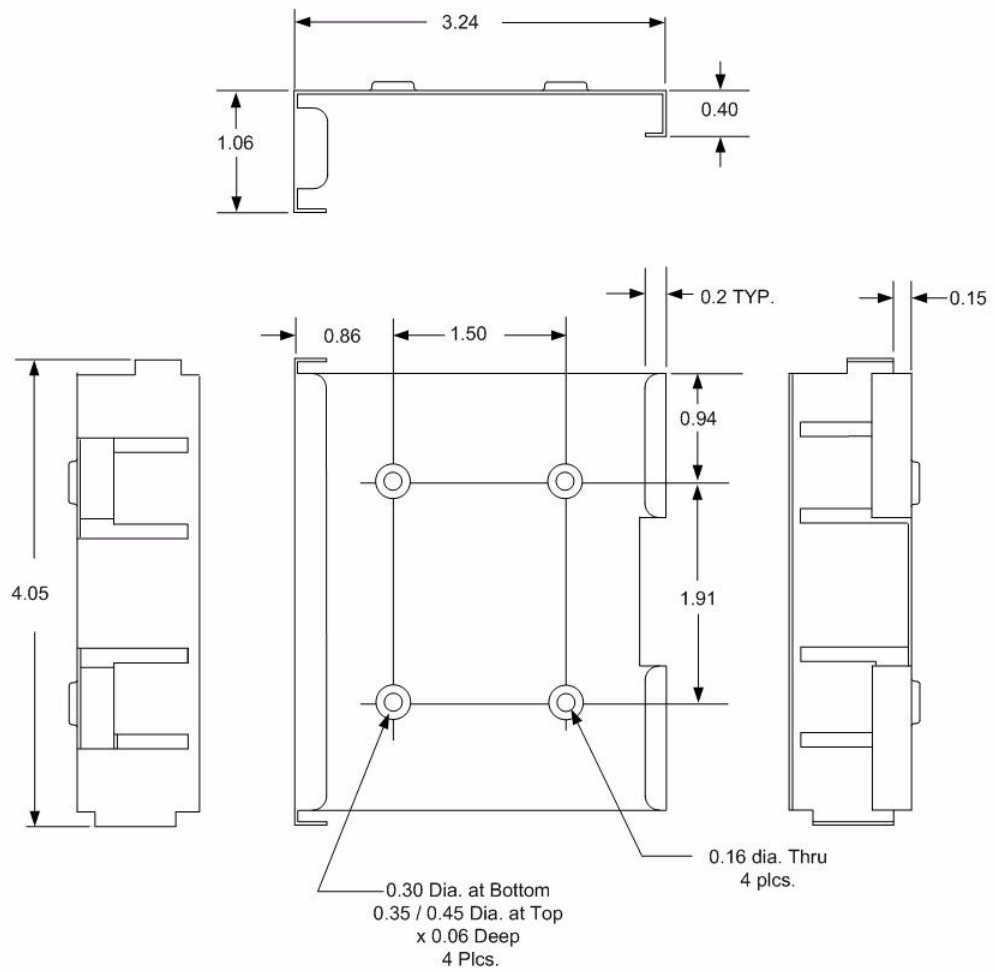

Figure 4-7: Mounting bracket installation



100-170-1015 - Raven XE Snap Bracket - Case Clamping

Figure 4-8: Mounting Bracket for Raven XE; Dimensions in Inches

## 5: Inputs, Relay Outputs, and Power Status

- Capturing External Events Using Inputs

The Raven XE has special features for use in an M2M environment. The Raven XE can be configured to monitor the input, respond to specific types of events, and even trigger a digital output. These features can be configured to meet your needs.

### Capturing External Events Using Inputs

While using a special power cable with I/O, the Raven XE is equipped with an I/O interface for use in instrumentation applications. This includes one digital input and one digital output which can be connected to sensors and switches to monitor status and remotely control equipment.

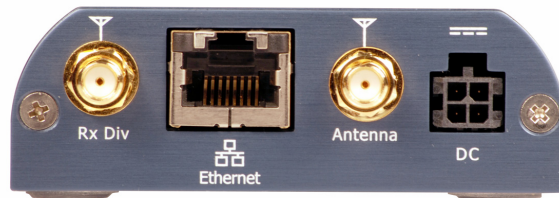

Figure 5-1: Raven XE Back Connections

### Digital Input

Digital input(s) can report a simple open or closed state by measuring contact closures on switches. Digital input(s) can be wired to the two ground signals via a switch. When the switch is open, the input will read "OPEN". When the switch is closed and the input is connected to ground, the input will read "CLOSED".

## Digital Input

### → Contact Closure

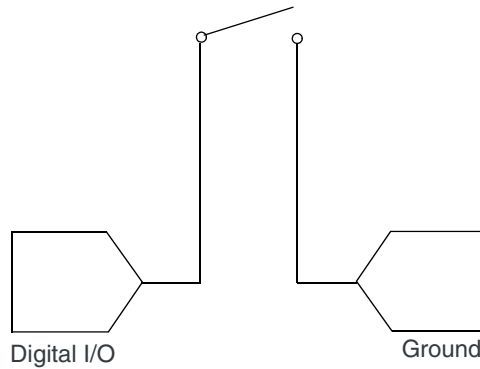

Figure 5-2: Digital Input Contact Closure

Examples of using the input with a switch to ground are:

- When a door or other latch is opened or closed.
- When counting pulses or other electronic events.
- When a gauge reaches a certain point.
- When a container fills or empties.
- When a switch or valve is opened or closed.
- When the tow bar is raised or lowered.
- When connected to a sensor, the level of fuel in a vehicle.
- When the trunk of a vehicle is opened or closed.
- When the ignition is turned on or off.

## Digital Output

### Example Relay Drive Circuit

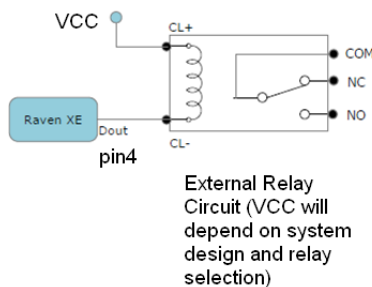

Figure 5-3: Digital Output



## Connecting Devices to the I/O Port

*Note: Before you install the Raven XE in its final location, be sure to cover all exposed wiring.*

You can purchase an optional I/O Power Cable for the Raven XE which can be used to attach devices to the combination I/O port and power connector. The harness has pre-wired leads to allow you to customize your own connections. The wires are paired and color-coded.



**Warning:** Risk of electric shock: Only use the supply voltages listed in this user guide.

Digital Input/Output	
Pin 3/4	
DIN1, DIN2/Output 1	
Function	Input
V Input "High" Range	2.0 to VCC+1 VDC
V Input "Low" Range	-0.3 to 1.5 VDC
Internal Pullup (no connection)	3.3 VDC
Function	Output
IOUT	+/-50mA
VOHmin (IOH - 16mA)	2.4V
VOHmin (IOH - 24mA)	2.3V
VOLmax (IOL - 24mA)	0.55V

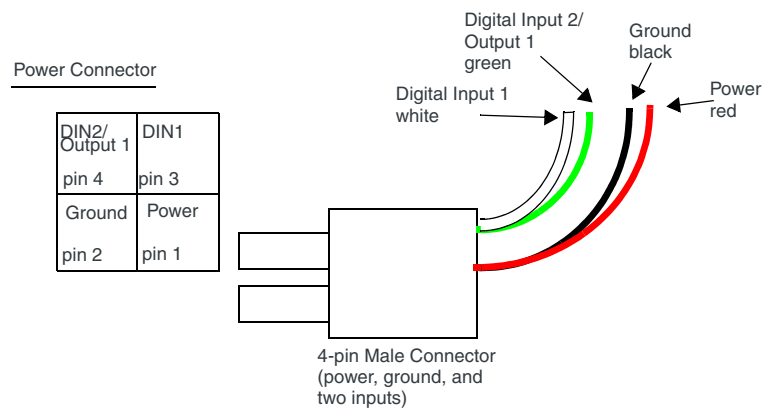

Figure 5-4: Power Connector Diagram

---

*Note: You can use the GX400 DC power cable (P/N 2000380) that includes a green wire for Pin 4.*

---

**Caution:** *Never apply an external voltage while in the Output mode. This will cause damage to the unit.*

---

## Monitoring the Input and Output

You can monitor the status of the digital inputs using ACEmanager or AT Commands, or with special reports sent by email, SMS, or other Event Reporting report types. In ACEmanager, select the I/O group.

Configuration	Value
<input type="checkbox"/> Relay 1 Initial Setting	OFF
<input type="checkbox"/> Relay 2 Initial Setting	OFF
<input type="checkbox"/> Coefficient for Analog 1	1.00
<input type="checkbox"/> Offset for Analog 1	0.00
<input type="checkbox"/> Units for Analog 1	
<input type="checkbox"/> Coefficient for Analog 2	1.00
<input type="checkbox"/> Offset for Analog 2	0.00
<input type="checkbox"/> Units for Analog 2	
<input type="checkbox"/> Coefficient for Analog 3	1.00
<input type="checkbox"/> Offset for Analog 3	0.00
<input type="checkbox"/> Units for Analog 3	
<input type="checkbox"/> Coefficient for Analog 4	1.00
<input type="checkbox"/> Offset for Analog 4	0.00
<input type="checkbox"/> Units for Analog 4	

Figure 5-5: ACEmanager : I/O

---

*Note: Refer to the ALEOS User Guide for configuring Raven XE I/O in ACEmanager.*

---

## >> 6: Connecting the Raven XE

- [ACEmanager](#)
- [Using a Terminal Application with AT Commands](#)
- [AT Commands](#)

The Raven XE, with its embedded ALEOS firmware, is a highly configurable device.

There are two options for configuring the Raven XE:

- Use the configuration and management applications of the AceWare suite, or
- Use a terminal emulator application such as HyperTerminal, PuTTY, etc.

### ACEmanager

To get a more expanded view of the other ACEmanager features, refer to the ACEmanager Guide.

A full listing of all the configuration commands for your modem is found in [Chapter 6](#) of the ALEOS User Guide.

### Using a Terminal Application with AT Commands

You can access and configure your Raven XE using a terminal emulator application such as Microsoft HyperTerminal, PuTTY, or others. The following directions are for HyperTerminal which is part of a standard installation of Windows XP.

1. Choose a name and icon for your connection
  - a. Choose a name for your connection, such as *Raven XE* or *Sierra Wireless AirLink Solutions*. The name and icon are only for your own reference so you can find the connection at a later date.

---

**Tip:** *If you want to have a connection saved for both local and remote, it is recommended the connection name reflect the connection type, i.e., Raven XE local.*

---

- b. Select OK.
2. At the Connect To window, using USB or serial:  
Using USB/Serial:
  - a. Select *COM1* or the COM port to which the gateway is connected, for the “Connect using” option.

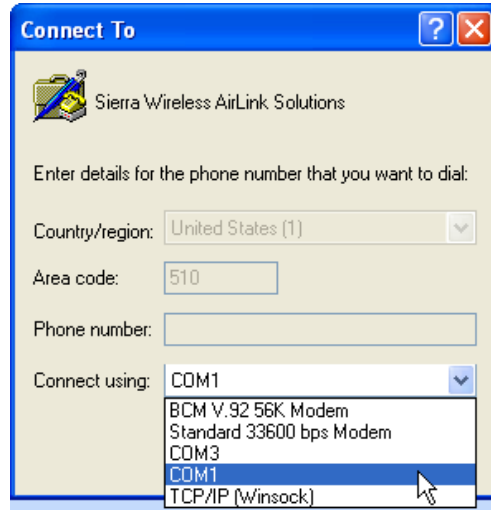

Figure 6-1: Connect To window

- b. Change or verify the settings when the COM1 Properties window displays:
  - Bits per Second: 115200 (default)
  - Data Bits: 8
  - Parity: None
  - Stop Bits: 1
  - Flow Control: Hardware.

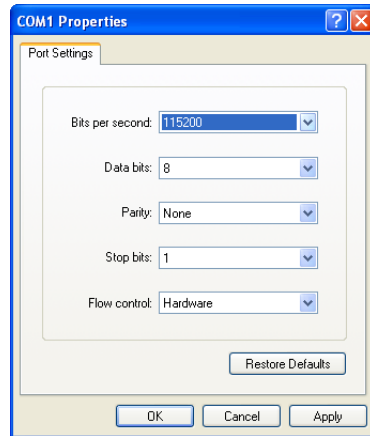

Figure 6-2: Port Settings at COM1 Properties

---

**Tip:** If you have configured the Raven XE for settings different than the defaults for Bits per second, Data bits, Parity, and/or Stop bits, you will need to use your changed settings.

---

- c. Select OK.

If using Ethernet:

- d. Select *TCP/IP (Winsock)* for “Connect using”.
- e. Enter the Raven XE’s internal IP address in “Host address”.

- f. Change the “Port number” to 2332.

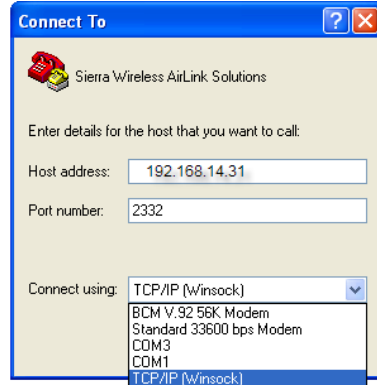

- g. Select OK.

3. You are now connected.

Connecting on USB/net will prompt you for a password.

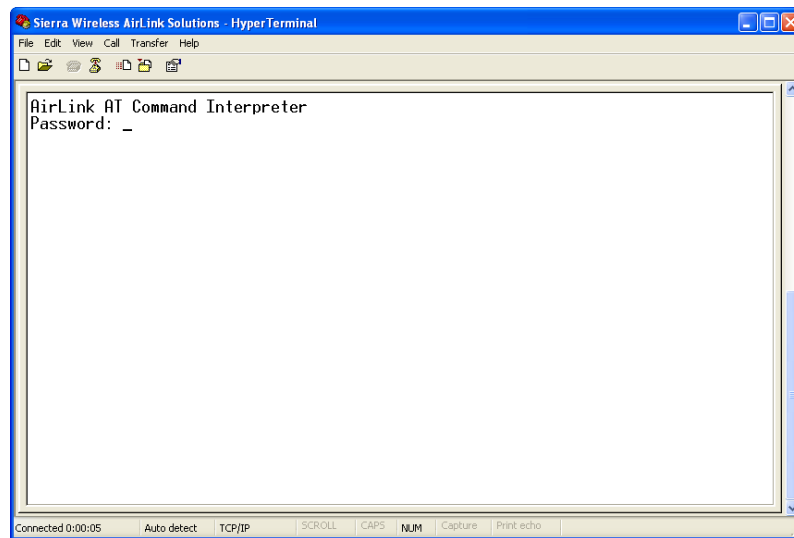

Figure 6-3: HyperTerminal : TCP/IP connected

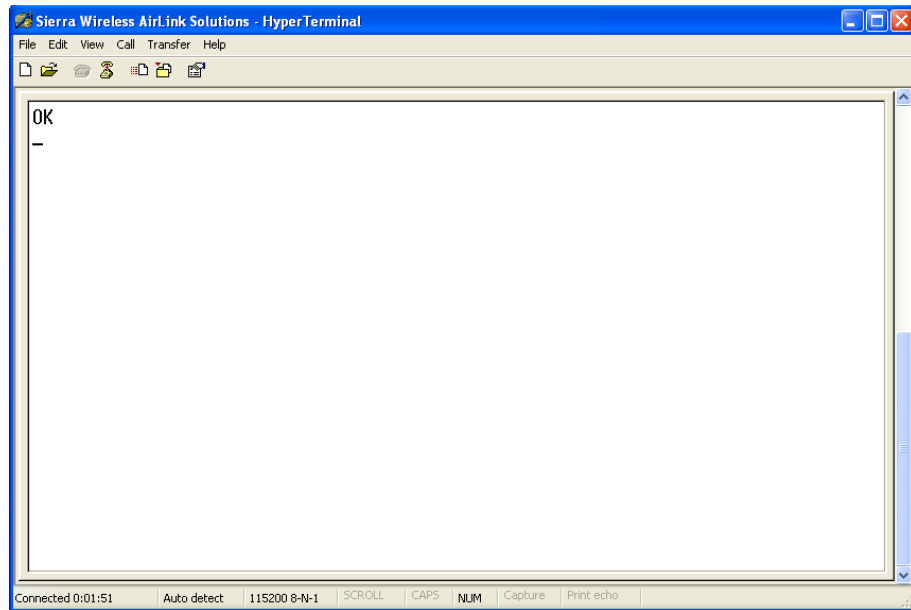

Figure 6-4: HyperTerminal : connected

- a. If you are prompted for a password, enter the default password *12345*.

---

**Tip:** *You will not be prompted for a password if you connect using a COM port.*

---

- b. Type *AT* and press *Enter*. You should get a reply of "OK" or "0".
- c. To see what you are typing as you type it, you will need to turn on the echo and verbose mode. Type *ATE1V1* and press *Enter*.
- d. If you get a reply of "OK", then you entered the command successfully. If you get a reply of "0" or "ERROR", try entering the command again.

## AT Commands

When using a terminal application, you will need to manually type in each command.

- For most commands, when entering them using a terminal connection, you will need to preface the command with AT (exceptions are noted), i.e., *ATA* which is listed as *A*.
- Some commands have specific parameters while other commands will take whatever you type.
- Required variable parameters are denoted with italicized text, example, *Dn*. The *n* is a variable.
- Acceptable parameters and/or specific formats are listed with each command.
- Most commands with parameters can be entered with ? to read the current value (e.g., *AT&D?* will respond with “2” if the default has not been changed).
- Optional parameters are denoted with square brackets [ ].
- AT Commands are not case sensitive. A capital “E” is the same as a lower-case “e”.
- When you are using a terminal connection, if you enter a command which is recognized by the Raven XE, it will respond with “OK”. If the command is not recognized, the response will be “ERROR”.
- Those commands applicable only to certain model numbers of the Raven XE will be noted.

---

**Caution:** *Symbols listed with commands, such as \*, /, &, or ?, are part of the command and must be included. Commands with symbols other than \* may require PassThru mode.*

---





## 7: Regulatory Information

# 7

### Federal Communications Commission Notice (FCC United States)

Electronic devices, including computers and wireless modems, generate RF energy incidental to their intended function and are therefore subject to FCC rules and regulations.

This equipment has been tested to, and found to be within the acceptable limits for a Class A digital device, pursuant to part 15 of the FCC Rules.

This equipment generates radio frequency energy and is designed for use in accordance with the manufacturer's user manual. However, there is no guarantee that interference will not occur in any particular installation.

If this equipment causes harmful interference to radio or television reception, which can be determined by turning the equipment off and on, you are encouraged to try to correct the interference by one or more of the following measures:

- Reorient or relocate the receiving antenna
- Increase the separation between the equipment and the receiver
- Connect the equipment into an outlet on a circuit different from that to which the receiver is connected
- Consult the dealer or an experienced radio/television technician for help
- This device complies with Part 15 of the Federal Communications Commission (FCC) Rules. Operation is subject to the following two conditions:
  1. This device may not cause harmful interference.
  2. This device must accept any interference received, including interference that may cause undesired operation.



**Warning:** *Changes or modifications to this device not expressly approved by Sierra Wireless could void the user's authority to operate this equipment.*

### Industry Canada

This Class A digital apparatus meets all requirements of the Canadian Interference Causing Equipment Regulations. Operation is subject to the following two conditions:

1. this device may not cause harmful interference, and
2. this device must accept any interference received, including interference that may cause undesired operation.

## Antenna Considerations

Although the antenna model(s) used with these devices meet(s) the Industry Canada Radio Frequency requirements, it is possible that the future customers may swap them for different ones without network provider's knowledge and approval. Such customers must be made aware of, and follow, the Radio Frequency requirements applied in this Technical Approval:

- RSS-102 "Radio Frequency Exposure Compliance of Radiocommunication Apparatus (All Frequency Bands)"
- RSS-129 "800 Mhz Dual-Mode CDMA Cellular Telephones"
- RSS-132e "Cellular Telephones Employing New Technologies Operating in the Bands 824-849 Mhz and 869-894 Mhz"
- RSS-133 r1 "2 GHz Personal Communications Services"

## RF Exposure

In accordance with FCC/IC requirements of human exposure to radiofrequency fields, the radiating element shall be installed such that a minimum separation distance of 20cm should be maintained between the antenna and the user's body.



---

**Warning:** *This product is only to be installed by qualified personnel!*

---

To comply with FCC/IC regulations limiting both maximum RF output power and human exposure to RF radiation, the maximum antenna gain must not exceed 5 dBi in the Cellular band and 4 dBi in the PCS band.

## EU

---

*Note: A distance of at least 20 cm must be maintained at all times between the antenna and the user.*

---

Sierra Wireless hereby declares that the Raven XE devices conform to all the essential requirements of Directive 1999/5/EC.

Products are marked with a CE and notified body number as shown here:

**CE 0984**

The Declaration of Conformity made under Directive 1999/5/EC is available for viewing at the following location in the EU community.

Sierra Wireless (UK), Limited  
Suite 5, the Hub  
Fowler Avenue  
Farnborough Business Park  
Farnborough, United Kingdom GU14 7JP

The device is a Class A device for use in a commercial environment.

## **WEEE Notice**



If you purchased a Raven XE in Europe, please make sure that the device is collected separately from general domestic waste at the end of its life. WEEE (Waste of Electric and Electronic Equipment) products may be recognized by their wheeled bin label on the product label.



